

## ACM4806E / PCM4806E IDEA Drive

### Specifications

Attribute	Value
Drive Input Voltage Range	12-48Vdc
Maximum Drive Current (per phase)	0.6Arms (Plus optional 30% boost during ramping)
Step Modes	Full, Half, ¼, 1/8, 1/16, 1/32, 1/64
Communications	USB (Mini B connector) RS-485
Digital I/O Voltage Range	5-24Vdc
Digital Inputs	4
Digital Sinking Outputs	4
Digital Output Maximum Sinking Current	200mA (each)
Digital Input Maximum Current	8mA (each)
Maximum Temperature	70°C (Measured at heat sink)
Program Storage Size-Type	85 Kbytes-Flash
Maximum Number of Stored Programs	85, Referenced by 10 character program names
Position counter range	64bit
Type of Ramping	Trapezoidal
Interrupt sources	4 inputs (rising, falling or both edges), internal position counter (when reaching a programmed position).

# ACM4806E IDEA Drive Engineering Drawings

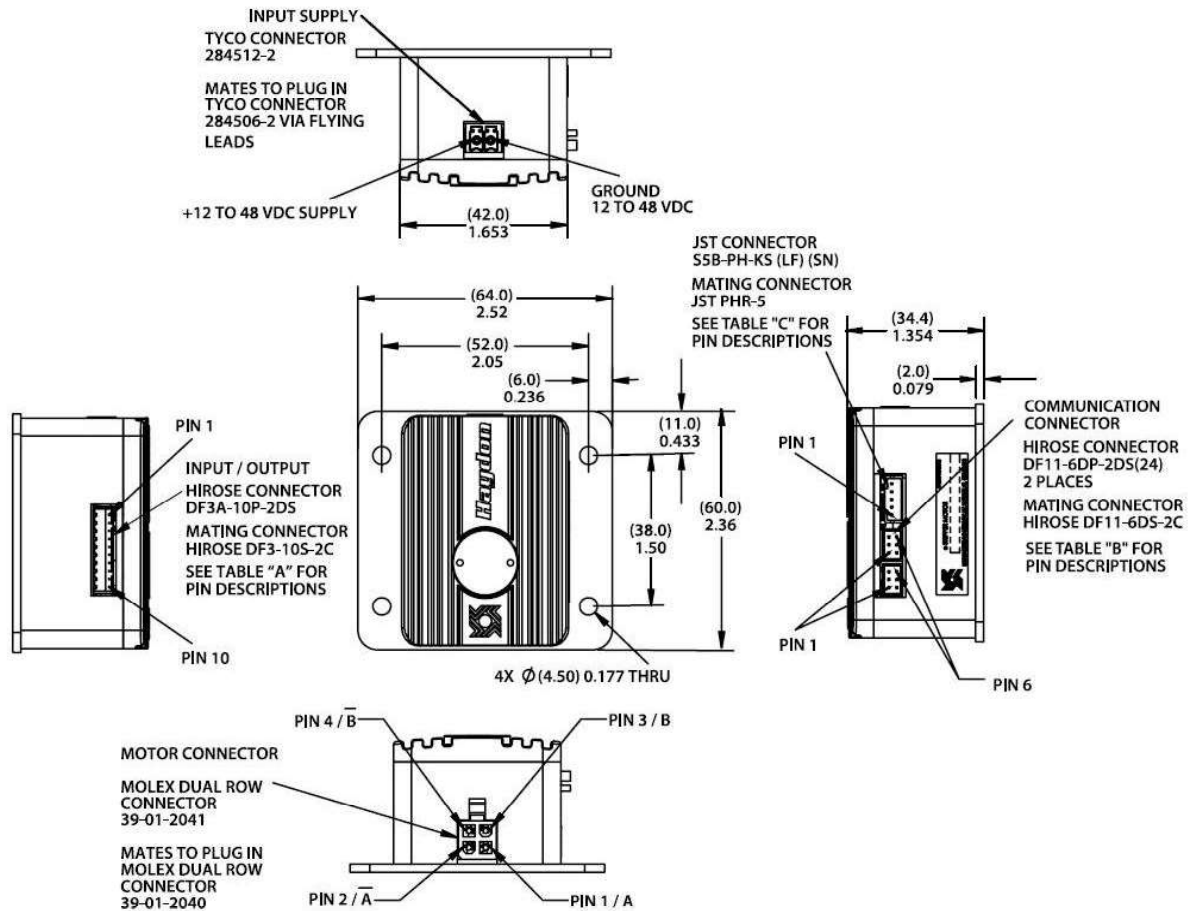

TABLE "A"

PIN POSITION	DESCRIPTION	NOTES
PIN 1	GROUND I/O SUPPLY	5 TO 24 VDC
PIN 2	+ I/O SUPPLY	5 TO 24 VDC
PIN 3	INPUT 1	
PIN 4	INPUT 2	
PIN 5	INPUT 3	
PIN 6	INPUT 4	
PIN 7	OUTPUT 1	
PIN 8	OUTPUT 2	
PIN 9	OUTPUT 3	
PIN 10	OUTPUT 4	

TABLE "B"

PIN #	DESCRIPTION
1	Y / NON-INVERTING DRIVER OUTPUT
2	Z / INVERTING DRIVER OUTPUT
3	GROUND
4	GROUND
5	A / NON-INVERTING RECEIVER INPUT
6	B / INVERTING RECEIVER INPUT

TABLE "C"

PIN #	DESCRIPTION
1	+5V
2	GROUND
3	INDEX / NO CONNECTION
4	"B" CHANNEL
5	"A" CHANNEL