

RGS Series Linear Rail with Hybrid 57000 Series Size 23 Linear Actuator Stepper Motors

RG Series linear rails are available:

- RGS10 Motorized with 57000 Series Size 23 Single and Double Stack hybrid motors
- RGW10 wide frame motorized with 57000 Series Size 23 Single and Double Stack hybrid motors

Driven by a Size 23 Hybrid motor, the 25.4 mm (1-inch) diameter splined carriage guide has been designed to carry a weight load up to 100 lbs (445 N). A high performance motion control system combines power and precision. The system combines many Haydon Kerk Motion Solutions patented motion technologies into a single integrated, linear motion control system. The Motorized RGS linear rails feature standard wear-compensating, anti-backlash driven carriages to insure repeatable and accurate positioning. All moving surfaces include Kerkite[®] engineered polymers running on Kerkote[®] TFE coating, providing a strong, stable platform for a variety of linear motion applications.

Technical specifications for 57000 Series Size 23 Hybrid Linear Actuator Stepper Motors are on page 3.

To determine what is best for your application see the Linear Rail Applications Checklist on page 5.

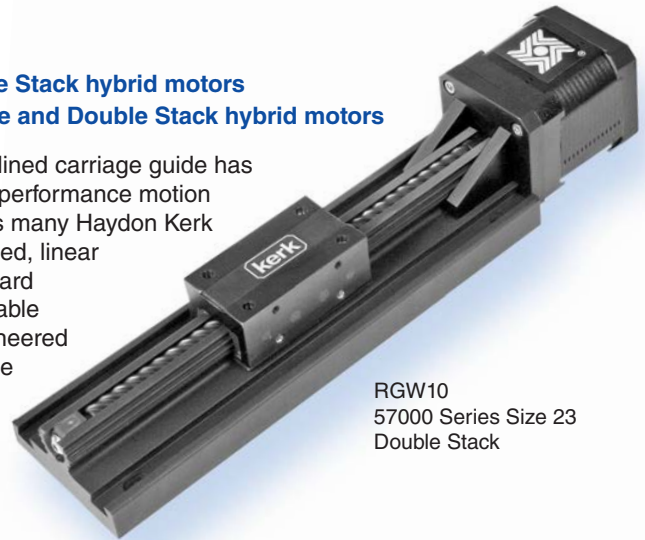

RGW10
 57000 Series Size 23
 Double Stack

Identifying the Motorized RGS part number codes when ordering

RG	S	10	K	-	M	0100	-	XXX
Prefix	Frame Style	Frame Size Load	Coating		Drive / Mounting	Nominal Thread Lead Code		Unique Identifier
RG = Rapid Guide Screw	S = Standard W = Wide sensor mount capability	10 = 100 lbs (445 N) (Maximum static load)	K = TFE Kerkote [®] X = Special (example: Kerkote with grease)		M = Motorized	0100 = .100-in (2.54) 0125 = .125-in (3.18) 0200 = .200-in (5.08) 0250 = .250-in (6.35) 0315 = .315-in (8.00) 0500 = .500-in (12.70) 0630 = .630-in (16.00) 1000 = 1.000-in (25.4) 1500 = 1.500-in (38.10) 2000 = 2.000-in (50.80)		Suffix used to identify specific motors (57000 Single/ Double Stack - or a proprietary suffix assigned to a specific customer application. The identifier can apply to either a standard or custom part.
		Carriage holes available in Metric sizes M3 M4 M5 M6						NOTE: Dashes must be included in Part Number (-) as shown above. For assistance or order entry, call our engineering team at 603 213 6290.

RGS10® with 57000 Series Size 23 Single and Double Stack linear motors
 Recommended for horizontal loads up to 100 lbs (445 N)

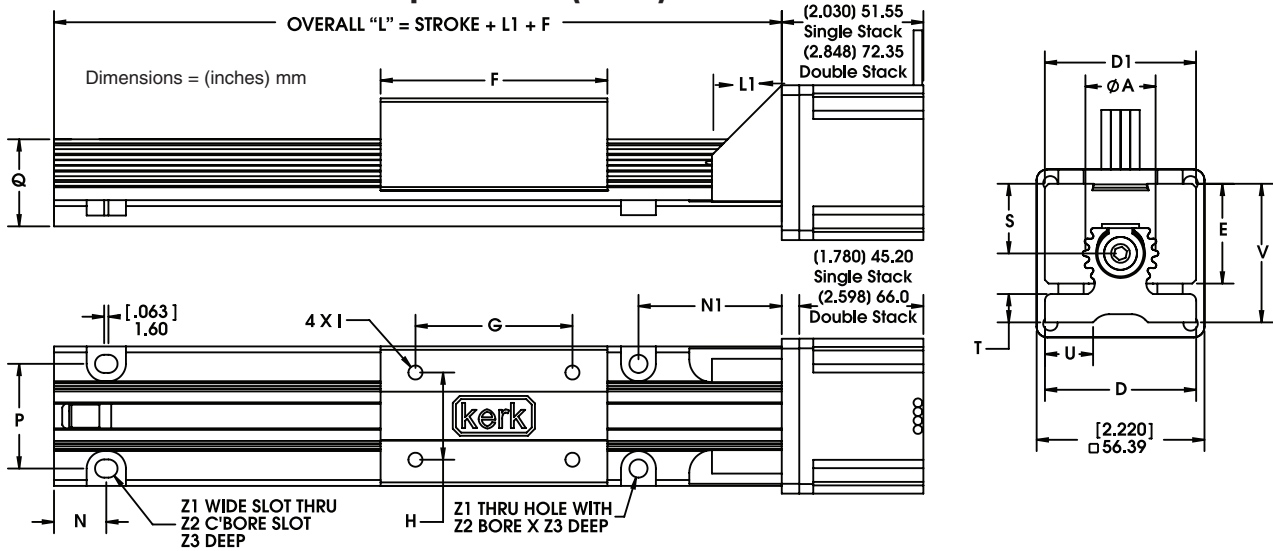

	A	D	D1	E	F	G	H	I*	L1	N	N1	P	Q	S	T	U	V	Z1	Z2	Z3
(inch)	(1.0)	(2.0)	((2.0)	(1.32)	(3.3)	(2.25)	(1.25)	1/4-20	(1.0)	(0.75)	(2.054)	(1.5)	(1.25)	(0.92)	(0.375)	(0.64)	(1.83)	(0.26)	(0.5)	(0.22)
mm	25.4	50.8	50.8	33.5	83.8	57.1	31.7	UNC	25.4	19.0	52.2	38.1	37.1	23.4	9.53	16.3	46.5	6.6	12.7	5.6

* Metric threads also available for carriage.

RGW10® with 57000 Series Size 23 Single and Double Stack linear motors
 Recommended for horizontal loads up to 100 lbs (445 N)

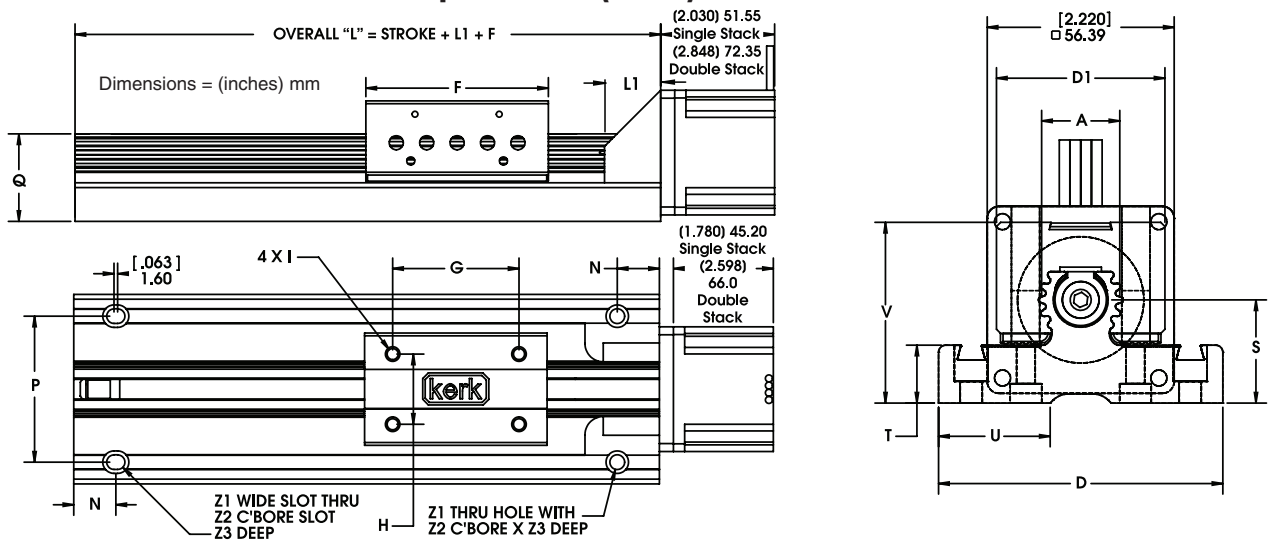

	A	D	D1	F	G	H	I*	L1	N	P	Q	S	T	U	V	Z1	Z2	Z3
(inch)	(1.0)	(3.38)	(2.0)	(3.3)	(2.25)	(1.25)	1/4-20	(1.0)	(0.75)	(2.6)	(1.56)	(1.22)	(0.69)	(1.33)	(2.15)	(0.26)	(0.4)	(0.43)
mm	25.4	85.9	50.8	83.8	57.1	31.7	UNC	25.4	19.0	66.0	39.6	31.0	17.5	33.8	54.6	6.6	10.2	10.9

* Metric threads also available for carriage.

RGW10 Sensor Mount Kit Part No. RGW10SK

Sensor mounting kits, based on a U-channel optical sensor, are available for the RGW Series. Each kit includes one flag, three sensor mounts, and all mounting hardware. Sensors are not included in the kit and must be ordered separately from the sensor manufacturer.

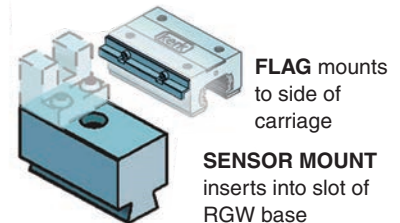

Specifications: Haydon® 57000 Series Size 23 Single Stack

Size 23: 57 mm (2.3-in) Hybrid External Linear Actuator (1.8° Step Angle)					
Wiring	Bipolar			Unipolar**	
Winding Voltage	3.25 VDC	5 VDC	12 VDC	5 VDC	12 VDC
Current (RMS)/phase	2.0 A	1.3 A	.54 A	1.3 A	.54 A
Resistance/phase	1.63 Ω	3.85 Ω	22.2 Ω	3.85 Ω	22.2 Ω
Inductance/phase	3.5 mH	10.5 mH	58 mH	5.3 mH	23.6 mH
Power Consumption	13 W				
Rotor Inertia	166 gcm ²				
Insulation Class	Class B (Class F available)				
Weight	18 oz (511 g)				
Insulation Resistance	20 MΩ				

Standard motors are Class B rated for maximum temperature of 130°C.

** Unipolar drive gives approximately 30% less thrust than bipolar drive.

Specifications: Haydon® 57000 Series Size 23 Double Stack

Size 23: 57 mm (2.3-in) Double Stack Hybrid External Linear Actuator (1.8° Step Angle)			
Wiring	Bipolar		
Winding Voltage	3.25 VDC	5 VDC	12 VDC
Current (RMS)/phase	3.85 A	2.5 A	1 A
Resistance/phase	0.98 Ω	2.0 Ω	12.0 Ω
Inductance/phase	2.3 mH	7.6 mH	35.0 mH
Power Consumption	25 W Total		
Rotor Inertia	332 gcm ²		
Insulation Class	Class B (Class F available)		
Weight	32 oz (958 g)		
Insulation Resistance	20 MΩ		



57000 Series Size 23 Single Stack External Linear

57000 Series Size 23 Double Stack External Linear

Hybrids: Stepping Sequence

	Bipolar	Q2-Q3	Q1-Q4	Q6-Q7	Q5-Q8
Unipolar	Q1	Q2	Q3	Q4	
Step					
1	ON	OFF	ON	OFF	
2	OFF	ON	ON	OFF	
3	OFF	ON	OFF	ON	
4	ON	OFF	OFF	ON	
1	ON	OFF	ON	OFF	

Note: Half stepping is accomplished by inserting an off state between transitioning phases.

Hybrids: Wiring

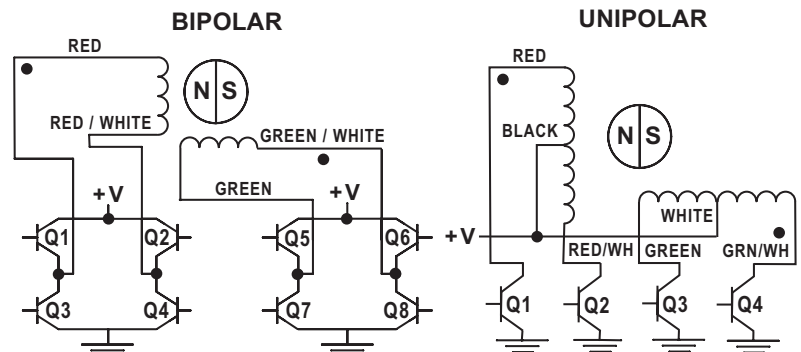

**Performance Curves:
 Haydon® 57000 Series
 Size 23 Single Stack**

FORCE vs. PULSE RATE
 Chopper • Bipolar
 100% Duty Cycle

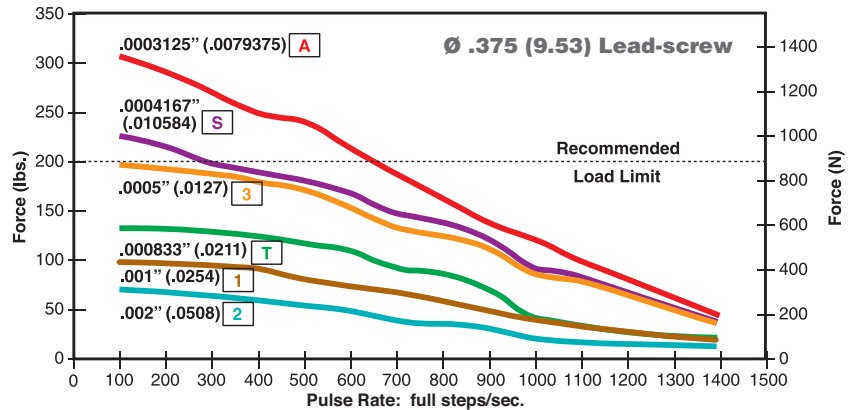

FORCE vs. LINEAR VELOCITY
 Chopper • Bipolar
 100% Duty Cycle

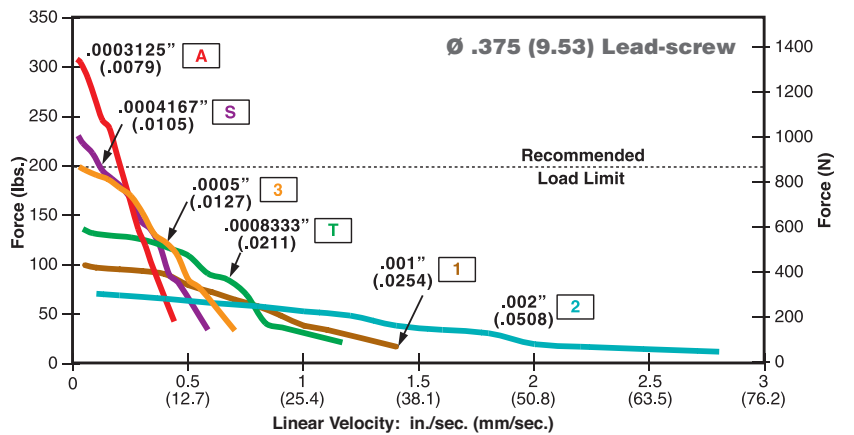

**Performance Curves:
 Haydon® 57000 Series
 Size 23 Double Stack**

FORCE vs. PULSE RATE
 Chopper • Bipolar
 100% Duty Cycle

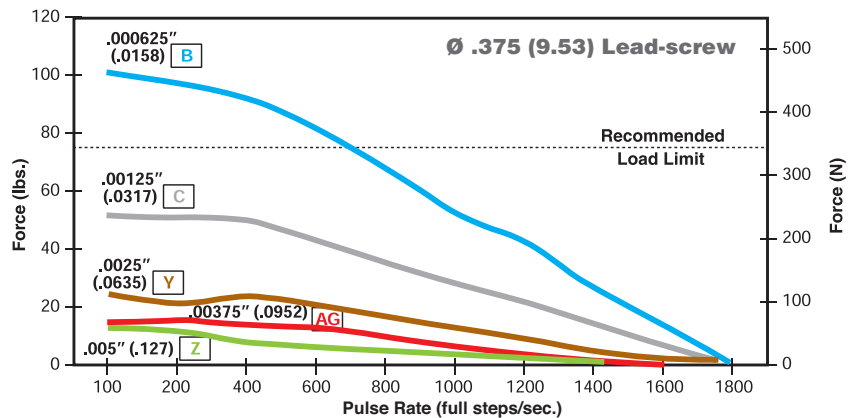

FORCE vs. LINEAR VELOCITY
 Chopper • Bipolar
 100% Duty Cycle

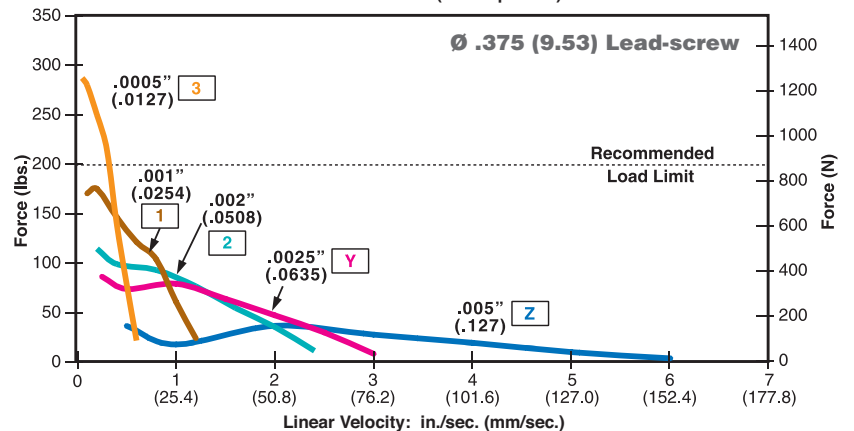

NOTE: All chopper drive curves were created with a 5 volt motor and a 40 volt power supply.
 Ramping can increase the performance of a motor either by increasing the top speed or getting a heavier load accelerated up to speed faster. Also, deceleration can be used to stop the motor without overshoot.
 With L/R drives peak force and speeds are reduced, using a unipolar drive will yield a further 30% force reduction.

Information needed to properly size a linear rail system

Haydon Kerk™ Linear Rail Systems are designed to be **precision motion devices**. Many variables must be considered before applying a particular rail system in an application. The following is a basic checklist of information needed that will make it easier for the Haydon Kerk engineering team to assist you in choosing the proper linear rail.

Linear Rail Application Checklist

- 1) **Maximum Load?** _____ (N or lbs.)
- 2) **Load Center of Gravity (cg) Distance and Height** (mm or inches)? See illustrations (A) (B) (C) below.
Dimensions mm / inch:

(A) _____ ... OR... (B) _____ AND... (C) _____

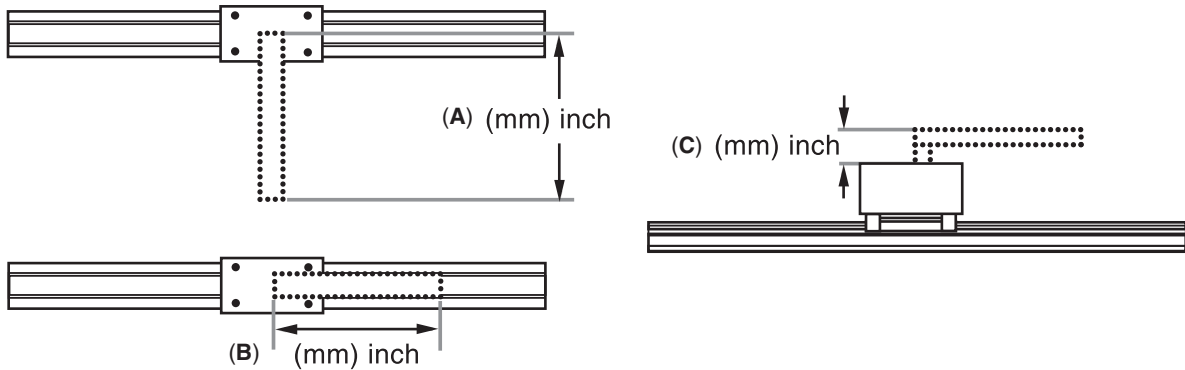

- 3) **Rail Mount Orientation?** The force needed to move the load is dependent on the orientation of the load relative to the force of gravity. For example, total required force in the horizontal plane (D) is a function of friction and the force needed for load acceleration ($F_f + F_a$). Total force in the vertical plane is a function of friction, load acceleration, and gravity ($F_f + F_a + F_g$).

Orientation:

- (D)
 (E) _____ °
 (F)
 (G)
 (H) _____ °

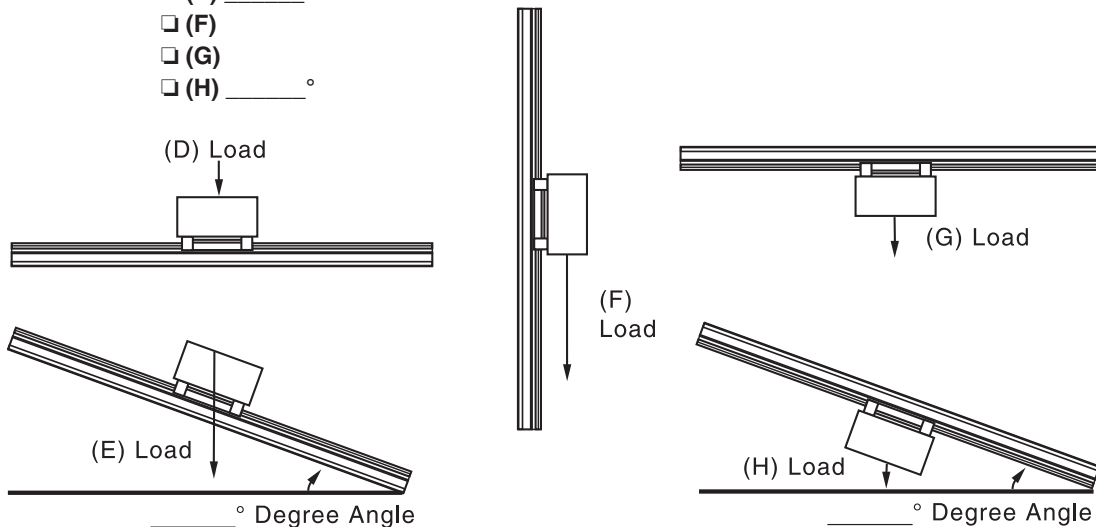

Linear Rail Application Checklist (Continued)

4) **Stroke Length to Move Load?** _____ (mm or inches)
 Overall rail size will be a function of stroke length needed to move the load, the rail frame size (load capability), the motor size, and whether or not an integrated stepper motor programmable drive system is added.

5) **Move Profile?**
 A **trapezoidal** move profile divided into 3 equal segments (J) is a common move profile and easy to work with. Another common move profile is a **triangular** profile divided into 2 equal segments (K).

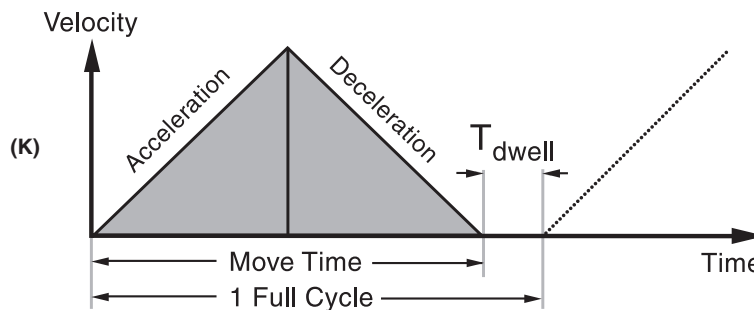
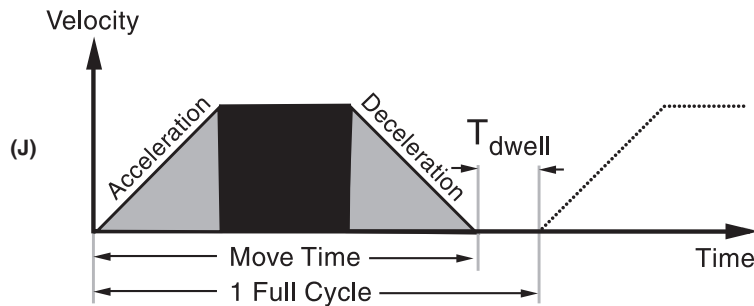

If using a **trapezoidal** (J) or **triangular** (K) move profile, the following is needed...

- a) Point to point move distance _____ (mm or inches)
- b) Move time _____ (seconds) including time of acceleration and deceleration
- c) Dwell time between moves _____ (seconds)

The trapezoidal move profile (J) is a good starting point in helping to size a system for prototype work.

A **complex** move profile (L) requires more information.

- a) Time (in seconds) including: $T_1, T_2, T_3, T_4, T_5 \dots T_n$ and T_{dwell}
- b) Acceleration / Deceleration (mm/sec^2 or $\text{inches}/\text{sec}^2$) including: $A_1, A_2, A_3 \dots A_n$

For more information call Haydon Kerk Motion Solutions Engineering at 203 756 7441.

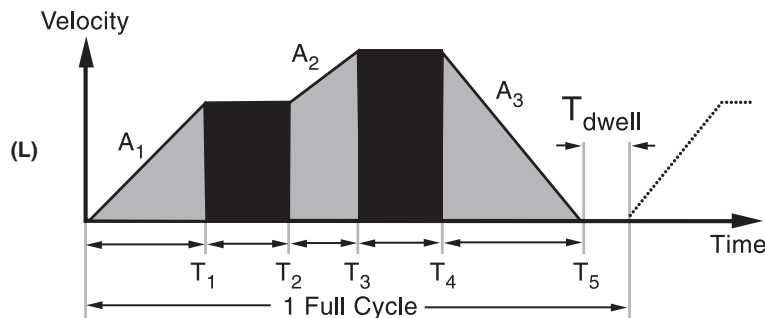

Linear Rail Application Checklist (Continued)

6) **Position Accuracy Required?** _____ (mm or inches)
 Accuracy is defined as the difference between the theoretical position and actual position capability of the system. Due to manufacturing tolerances in components, actual travel will be slightly different than theoretical "commanded" position. See figure (M) below.

7) **Position Repeatability Required?** _____ (mm or inches)
 Repeatability is defined as the range of positions attained when the rail is commanded to approach the same position multiple times under identical conditions. See figure (M) below.

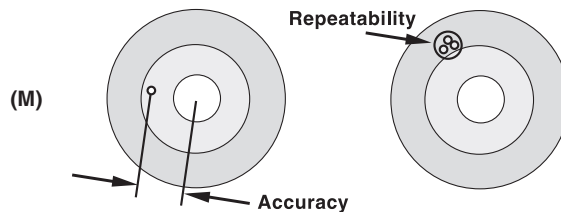

8) **Positioning Resolution Required?** _____ (mm/step or inches/step)
 Positioning resolution is the smallest move command that the system can generate. The resolution is a function of many factors including the drive electronics, lead screw pitch, and encoder (if required). The terms "resolution" and "accuracy" should never be used interchangeably.

9) **Closed-Loop Position Correction Required?** YES NO
 In stepper motor-based linear rail systems, position correction is typically accomplished using a rotary incremental encoder (either optical or magnetic).

10) **Life Requirement?** (select the most important application parameter)
 a) Total mm or inches _____
 ... or ... b) Number of Full Strokes _____
 ... or ... c) Number of Cycles _____

11) **Operating Temperature Range** _____ (°C or °F)
 a) Will the system operate in an environment in which the worst case temperature is above room temperature?
 b) Will the system be mounted in an enclosure with other equipment generating heat?

12) **Controller / Drive Information?**
 a) Haydon Kerk IDEAT[™] Drive (with Size 17 Stepper Motors only)
 b) Customer Supplied Drive... Type? Chopper Drive L / R Drive
 Model / Style of Drive: _____

13) **Power Supply Voltage?** _____ (VDC)

14) **Step Resolution?** a) Full Step b) Half-Step c) Micro-Step

15) **Drive Current?** _____ (A_{rms} / Phase) and _____ (A_{peak} / Phase)

16) **Current Boost Capability?** _____ (%)