



## Industrial motor controller for brushed DC motors 24 VDC

Design for output currents up to 8 A

Control with the following functions:

- reversal of direction of rotation
- overload shut-down
- short circuit detection

To snap onto the DIN rail EN 50022

Unit width: 22,5 mm

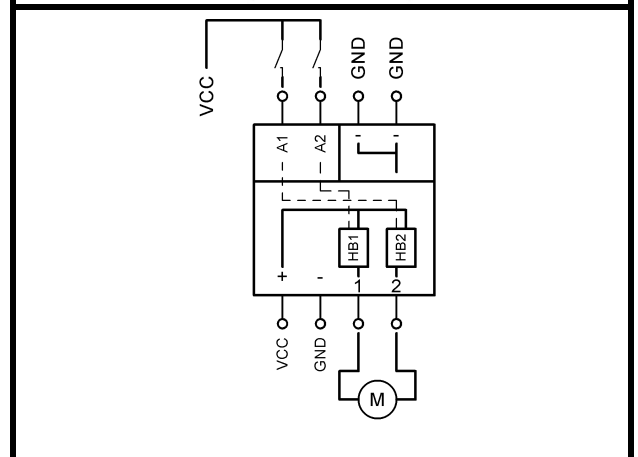

<b>Type</b>	<b>MAXI-MWF-8-30</b>	
<b>Article number</b>	<b>06.04.209</b>	
<b>Operating data:</b>		
Nominal voltage	$U_{nom}$	24,0 VDC
Supply voltage	$V_{CC}$	10 .. 35 VDC
Control inputs	$U_{DI}$	24,0 VDC
Quiescent current typ.	$I_0$	13 mA
<b>Technical data: load circuit</b>		
Max. current / continuous load current typ	$I_{max}/I_{con}$	15 / 8 A
Max. total current		TBD
Short circuit current detection typ	$I_{SC}$	80 A
Shut-down time after short circuit typ.	$t_{sc}$	100 $\mu$ s
Power stage driver		MOS-FET
<b>Other data</b>		
Dimensions		22,5 x 75 x 102 mm
Connectors		screw terminal cross section 0,2 – 2,5 mm <sup>2</sup>
Permissible ambient temperature	$T_{amb}$	-20 .. +50 °C
Temperature monitoring / overvoltage protection		yes / yes
Short-circuit-proof / overload protection		yes / yes
Status indicator: dir1 / dir2		LED1 yellow / LED2 red
Dynamic brake (Armature short circuit)		no
Galvanic isolation		no

Other data	
Installation position / Assembly	any / top-hat rail EN 50022
Installation place, typical	Switch cabinet
Mountable side by side	Conditional, depending on load current and ambient temperature
Storage temperature	-30 .. +85 °C
Permissible humidity	to 95 %, non-condensing
Weight	TBD
Hazardous substance norm	RoHS2
EMC interference immunity	EN 61000-6-2:2016
EMC emitted interference	EN 61000-6-3:2007 + A1:2011

Technical data: digital input	
High-Signal typ.	$U > 6\text{ V}$
Low-Signal typ.	$U < 3\text{ V}$
Impedance typ.	$R_{DI}$ 3,3 kΩ

Flammability	
Housing, terminal, printed circuit board	UL94-HB

**Description**

The module MAXI-MWF-8-30 is a two-quadrant DC motor control for use in an industrial environment. It guarantees the switching on and off of motors. The motor stops always without dynamic braking.

**Typical applications:**

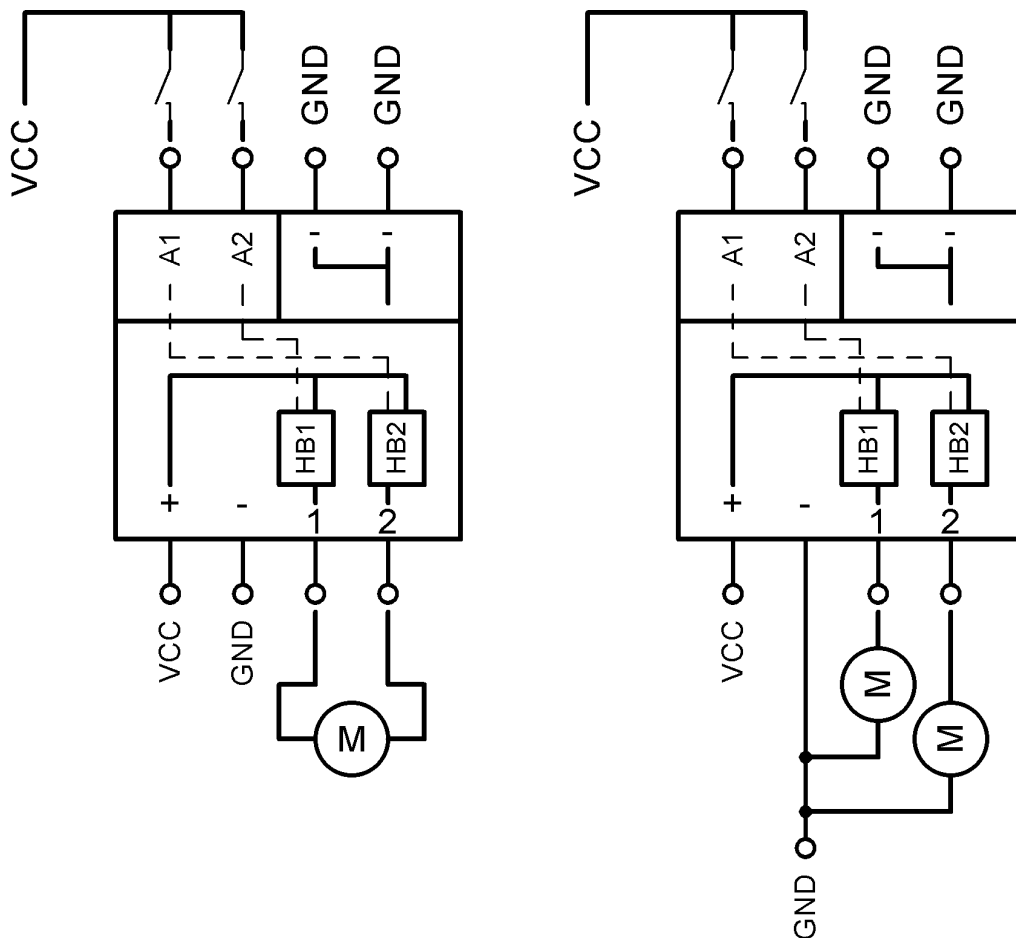

**Continuous load current / total current**      **Overload/over temperature switch off**

When operating one motor, the continuous load current specified in the technical data applies.

The device has an integrated overload and over temperature detection. If an event occurs, the motor will be switched off. After cooling down of the device the motor restarts automatically.

When operating 2 motors the total current depends on various factors that must be determined depending on the application. E.g.: ambient temperature, duty cycle, installation situation. The maximum specified total current must not be exceeded.

**Short circuit detection**      **Dynamic brake**

If a short circuit is detected from the device the motor switches off with dynamic braking and blocks the actual half bridge. The motor can be restarted by resetting the direction signal.

The motor control has no dynamic break.

**Terminal diagram**

A1	A2	-	-
○	○	○	○
I	II	III	III
+	-	1	2

  

<b>A1</b>	<b>A2</b>	-	-
Digital input „dir1“ (p-switch)	Digital input „dir2“ (p-switch)	GND for Digital input	GND for Digital input
<b>+</b>	<b>-</b>	<b>1</b>	<b>2</b>
Supply VCC	Supply GND	Motor terminal 1 Switched on from digital input A2	Motor terminal 2 Switched on from digital input A1

**State table**

Direction „dir1“ (A1)	Direction „dir2“ (A2)	Motor terminal „1“	Motor terminal „2“	Function	LED „I“ yellow	LED „II“ red
0	0	open	open	stop	OFF	OFF
1	0	GND	VCC	Dir1	ON	OFF
0	1	VCC	GND	Dir2	OFF	ON
1	1	open	open	stop	ON	ON

**Dimensional drawing**

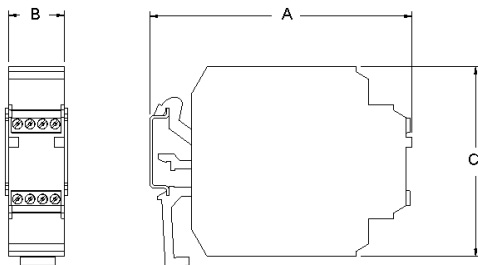

A = 102 mm; B = 22,5 mm; C = 75 mm

## Safety notes

### Maximum operational data

The maximum operating data may not be exceeded.

### Installation

The installation and start-up must be performed by specialist personnel exclusively.

All affected components must be disconnected from the mains.

### Start-up

For the first start-up, the motor should be operated without load.

### Risk of death

Do not touch live parts after switching on!

The assembly must be operated exclusively on safety extra-low voltage. With operation on extra-low voltage (e.g. via autotransformer), death or injury can occur.

### Fire protection

The assembly must be installed in a switch cabinet, which is suitable as a fire protection enclosure.

The assembly must be safeguarded with a pre-fuse aligned with the nominal data.

### Field of application

The assembly may only be used as intended.

Other components must be checked for their approvals and regulations.

### Safety devices

An additional safety device must be used to bring the system into a safe state in case of a cable break, incorrect operation, failure of the control/controller unit.

### EMC / EMI

The wiring must be done according to EMC / EMI standards. If necessary, shielded cables and EMC suppressors must be used for the connected consumer.

For operation in a public low-voltage distribution network, the module must be supplied with an approved AC adapter.

If the module is supplied with an AC adapter, other equipment, operated on the same power supply, must be suitable for use in industrial environments.

### Repairs

Repairs must be performed by authorised persons exclusively. With unauthorised opening, the warranty cover is voided and this may also result in danger for the user and for the system.

### Maintenance

The assembly is wear-free by design.

For modules **with** cooling openings free air circulation must be checked at the cooling openings or on the housing at regular intervals. If necessary, the cooling holes / the housing must be cleaned.

Good ventilation must be ensured.

## contact details



ready-to-use motor control solutions  
electronics design & manufacturing

### KALEJA GmbH

Strübelweg 14

73553 Alfdorf, Germany

Phone: +49 7172 93711 0

Fax: +49 7172 93711 90

E-Mail: [info@kaleja.com](mailto:info@kaleja.com)

[www.kaleja.com](http://www.kaleja.com)