

DCK31

Als 12 V und 24 V Motor mit Entstörung und Hall-Sensoren



Technische Beschreibung

Motorgehäuse

Magnetfeld

Getriebeart

Getriebegehäuse

Zahnradmaterial

Getriebebeschmierung

Schnittstelle mechanisch

Schnittstelle elektrisch

Sensor

Thermoschutz

Entstörung

Stahlblech tiefgezogen & korrosionsgeschützt

Permanentmagnet

Schneckenradgetriebe

Zinkdruckguss

KST, Metall

Fett, Dauerschmierung

Antriebswelle

Stecker

optional

optional

optional

Anwendungen

Industrie

Garagentor- und Türöffner, Pumpen, Schmiertechnik, Haushaltsgeräte, Linearantriebe

Automobil

Heckklappenverstellung

Info

GMK · GMM

GMP · CM3-4

GMAG

GMPI

CM3G

GMPD

GMPG

SWMP

DCK31

DCK35

SW2L

SWMV

SWMG

SW3K



Abbildung zeigt linke Getriebeausführung

Anschlüsse



Produktmatrix

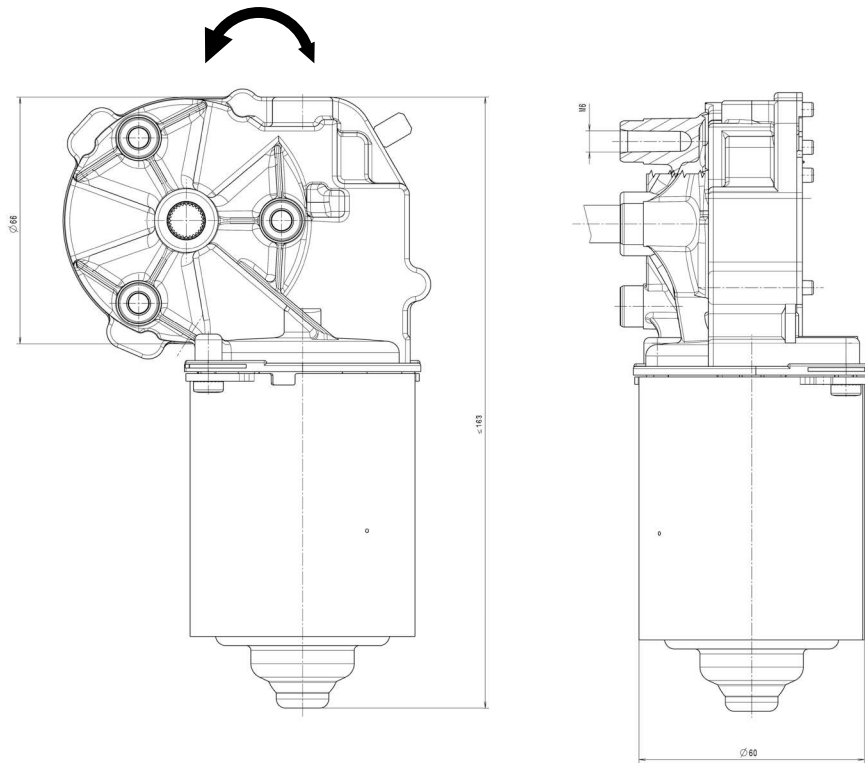
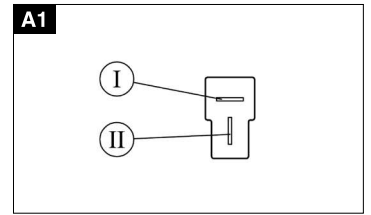
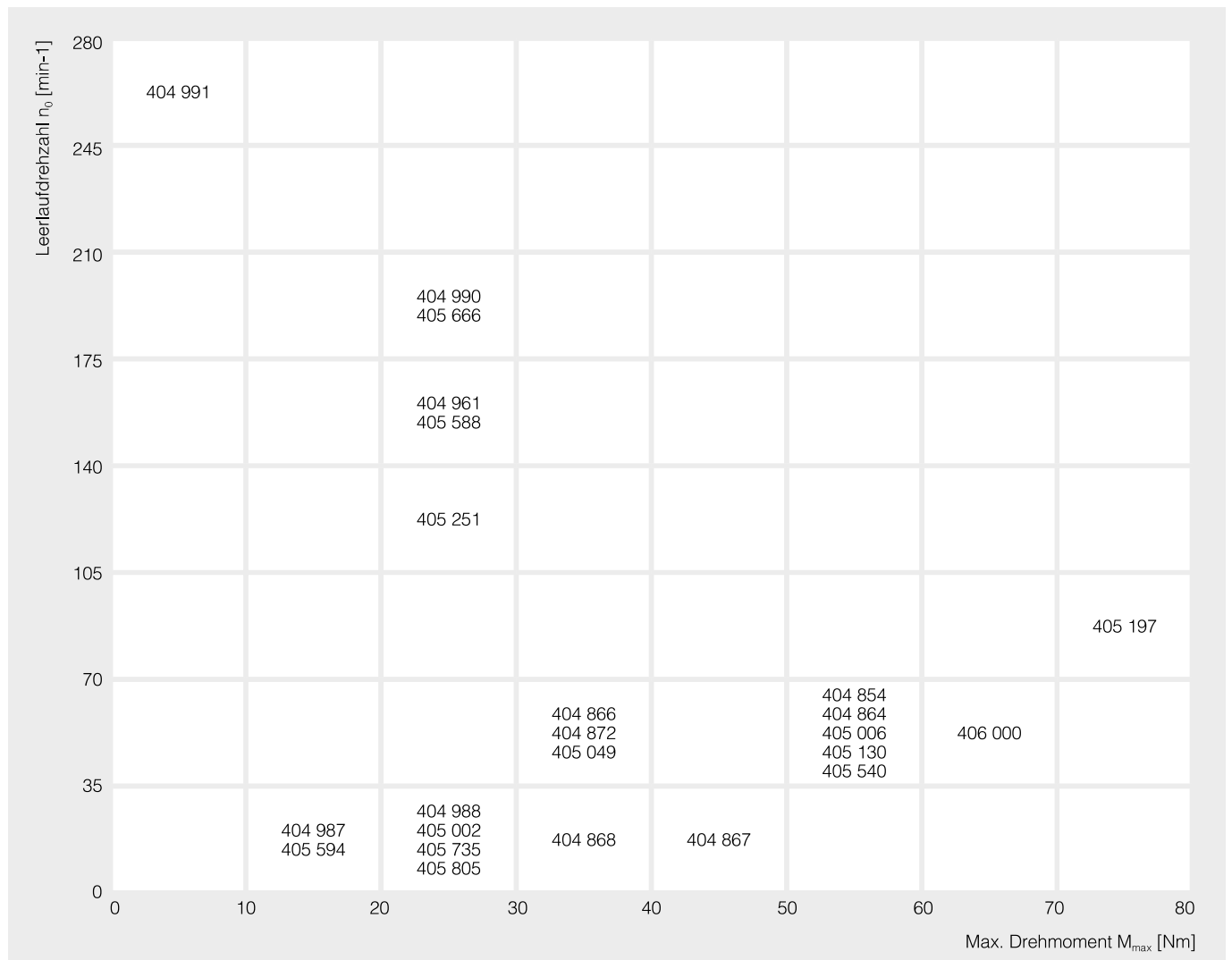

- Info
- GMK · GMM
- GMP · CM3-4
- GMAG
- GMP1
- CM3G
- GMPD
- GMPG
- SWMP
- DCK31**
- DCK35
- SW2L
- SWMV
- SWMG
- SW3K

Übersicht

Typ	Nennspannung	Max. Drehmoment	Leerlaufdrehzahl	Nennleistung	Nennstrom	Leerlaufstrom	Max. Strom	Hallsensoren	Untersetzung	Zahnradwerkstoff	Thermoschalter	Entstörung	Getriebegehäuse	Kennlinie	Welle	elektr. Anschluss
Typ	V	Nm	min ⁻¹	W	A	A	A	N/1/2	xx:x	D/M	J/N	J/N	lh/rh	K	W	A
404 854	24,0	52,0	63,0	74,0	3,1	2,0	28,1	1	69:1	K	N	J	lh	K7	W1	A1
404 864	24,0	51,1	66,0	75,0	3,1	1,8	30,6	N	69:1	K	N	J	rh	K8	W2	A1
404 866	24,0	33,7	50,0	139,0	7,7	2,5	24,3	N	69:1	K	N	J	rh	K9	W3	A1
404 867	24,0	49,9	35,0	65,0	2,7	2,5	14,8	N	69:1	K	N	J	rh	K10	W4	A1
404 868	24,0	37,0	20,0	32,2	1,3	0,8	9,5	N	69:1	K	N	J	rh	K11	W5	A1
404 872	24,0	34,0	36,0	36,0	1,5	1,4	10,0	N	69:1	K	J	J	lh	K12	W6	A1
404 961	24,0	28,0	160,0	92,0	3,8	3,0	36,3	2	53:2	K	N	J	lh	K4	W7	A1
404 987	24,0	17,0	15,0	31,0	1,3	0,7	4,6	2	78:1	M	N	J	rh	K6	W8	A1
404 988	24,0	28,0	35,0	55,0	2,3	1,5	12,8	2	69:1	K	N	J	rh	K13	W9	A1
404 990	24,0	21,0	195,0	160,0	6,7	3,0	30,0	2	53:2	K	N	J	rh	K18	W10	A1
404 991	24,0	7,4	270,0	120,0	5,0	2,0	16,9	1	41:4	K	N	J	lh	K5	W11	A1
405 002	12,0	28,0	21,0	25,1	2,1	1,5	14,8	N	69:1	K	N	J	rh	K1	W5	A1
405 006	24,0	52,3	63,0	74,0	3,1	2,2	28,0	2	69:1	K	N	J	lh	K7	W12	A1
405 049	12,0	33,5	45,0	79,0	6,6	3,0	31,3	N	69:1	K	N	J	rh	K2	W1	A1
405 130	24,0	54,0	46,0	102,0	4,3	2,5	29,9	1	69:1	K	N	J	lh	K14	W13	A1
405 197	24,0	78,0	88,0	113,0	4,7	3,0	66,0	1	69:1	K	N	J	lh	K15	W1	A1
405 251	24,0	27,6	120,0	137,0	5,7	2,0	27,9	1	53:2	K	N	J	lh	K16	W7	A1
405 540	24,0	51,8	63,5	74,0	3,1	2,2	27,6	1	69:1	K	N	J	lh	K7	W1	A1
405 588	24,0	28,4	160,0	92,0	3,9	3,0	36,4	2	53:2	K	N	J	lh	K4	W10	A1
405 594	24,0	17,0	14,5	31,0	1,3	0,8	5,2	2	78:1	M	N	J	rh	K6	W14	A1
405 666	24,0	21,2	195,0	160,0	6,7	3,0	30,4	2	53:2	K	N	J	rh	K18	W10	A1
405 735	12,0	26,3	21,0	30,0	2,5	1,2	13,8	N	78:1	M	N	J	rh	K3	W8	A1
405 805	24,0	27,8	17,0	36,0	1,5	1,5	5,4	2	69:1	K	N	J	rh	K17	W1	A1
406 000	24,0	64,0	69,0	120,0	5,0	2,4	46,0	1	69:1	K	N	J	lh	K19	W1	A1

DCK31

Kennlinien

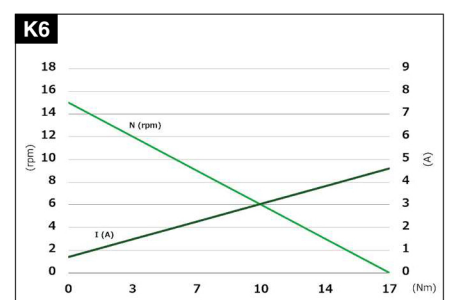
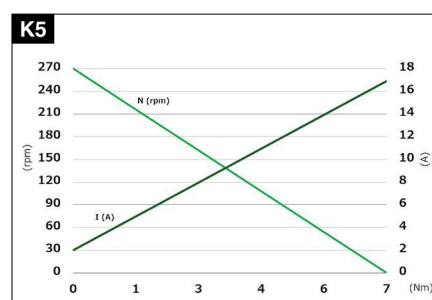
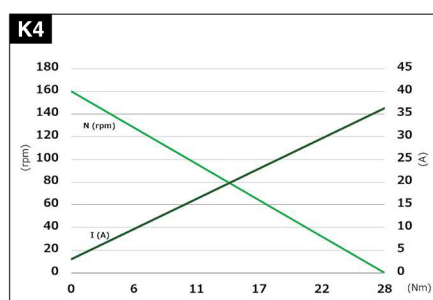
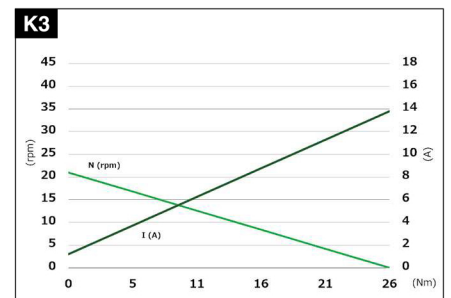
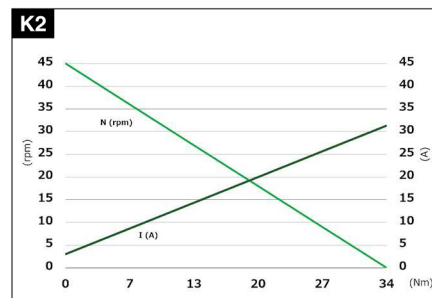
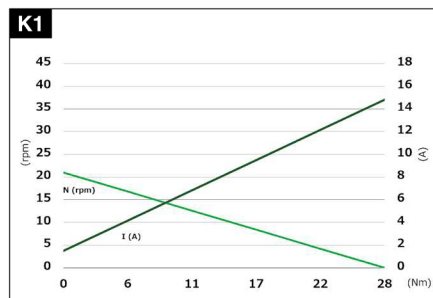

Kennlinien

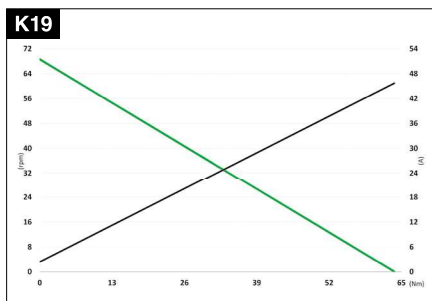
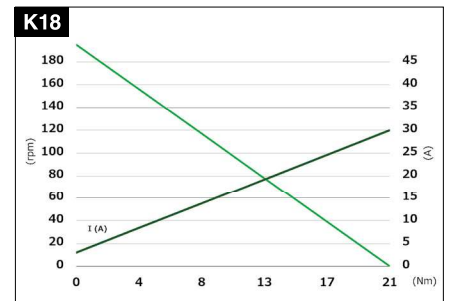
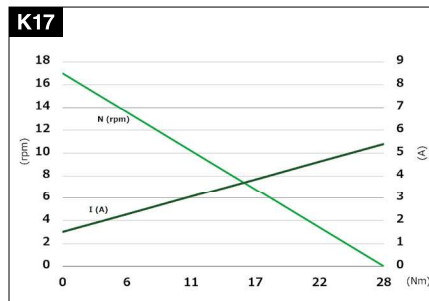
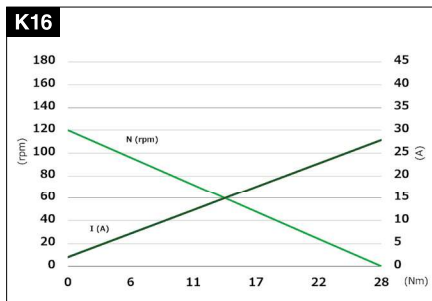
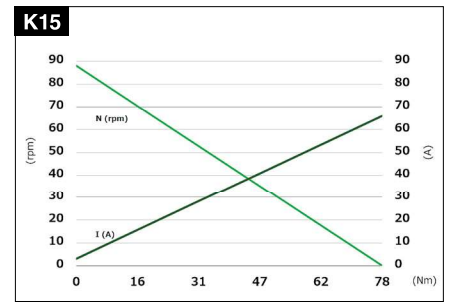
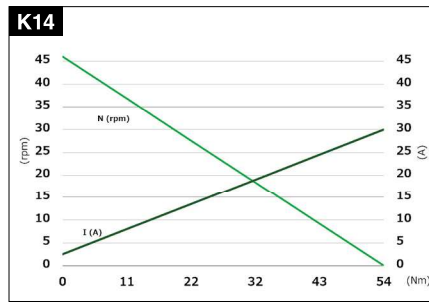
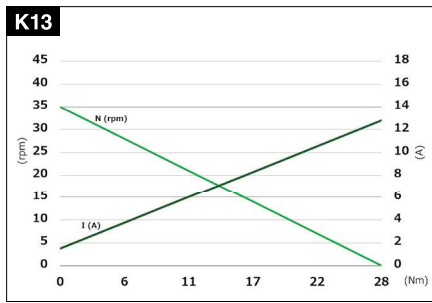
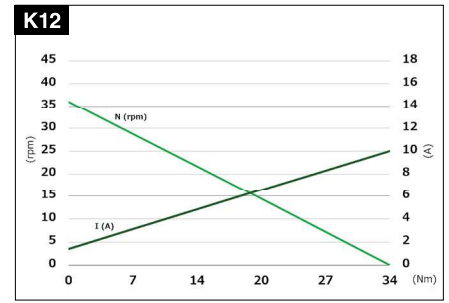
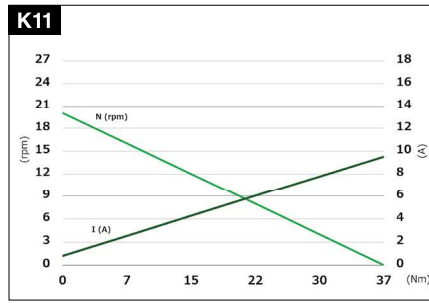
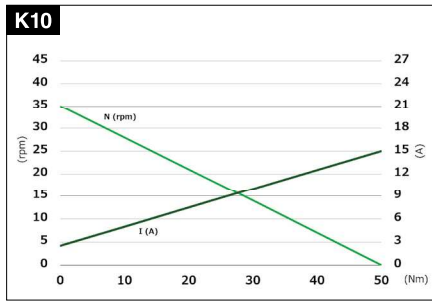
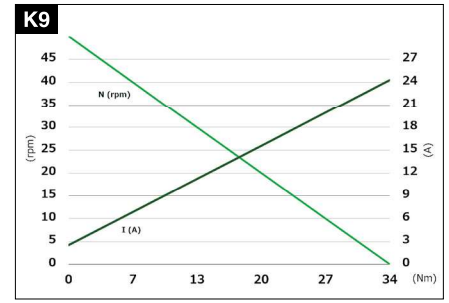
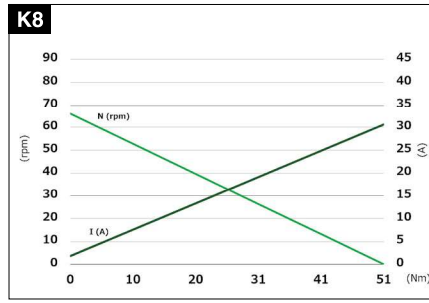
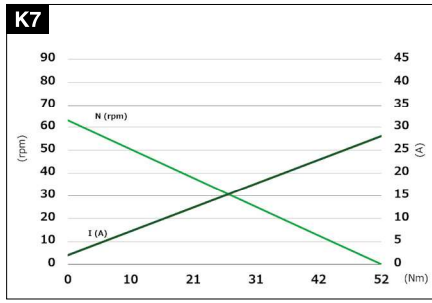

- Info
- GMP · CM3-4
- GMMK · GMM
- GMAG
- GMP1
- CM3G
- GMPD
- GMPG
- SWMP
- DCK31**
- DCK35
- SW2L
- SWMV
- SWMG
- SW3K

Wellen

Info

GMK · GMM

GMP · CM3-4

GMAG

GMP1

CM3G

GMPD

GMPG

SWMP

DCK31

DCK35

SW2L

SWMV

SWMG

SW3K

