

Motor M42 with worm gear SN17

- Aluminium gearhousing, hardened steel worm wheel, permanent grease lubrication, output with ball bearing, optional second shaft or output shaft left
- Other reductions, output shaft or connection cable on request

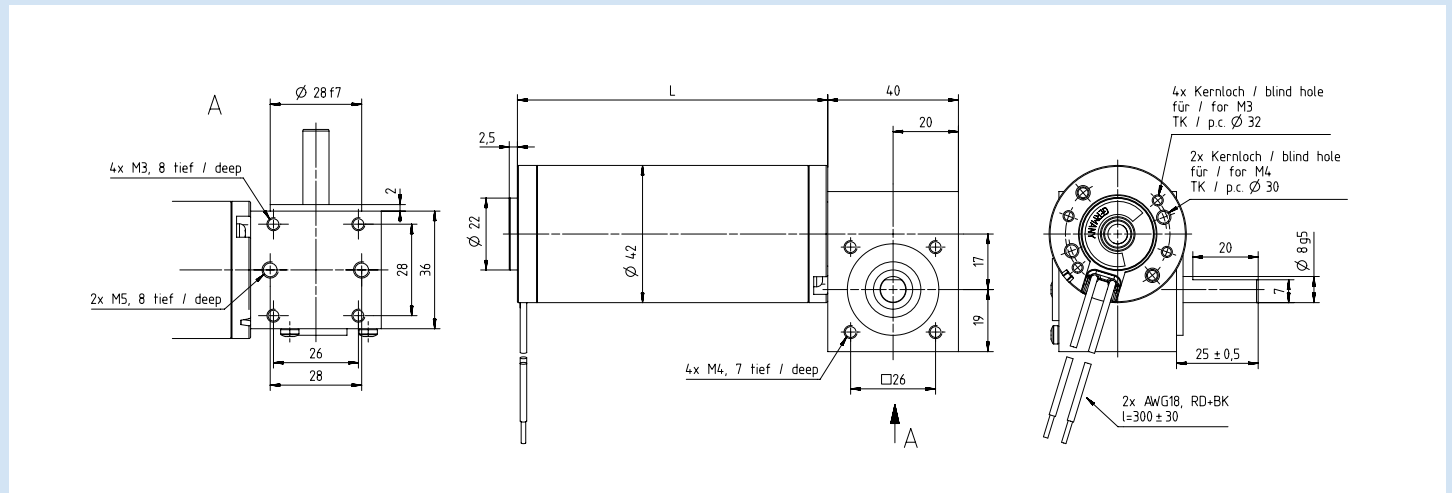

Gear reduction table M42xXX/I+ SN17

Application on request

Gear reduction	Efficiency of the gear	Speed at motor-speed 3000rpm	Nominal torque in S1-operation				
			M42x15/I L2 = 70 mm	M42x20/I L2 = 75 mm	M42x30/I L2 = 85 mm	M42x40/I L2 = 95 mm	
[i = x:1]	[%]	[1/min]	[Ncm]	[Ncm]	[Ncm]	[Ncm] 12V	[Ncm] 24V
10	69	300	27.6	34.5	44.9	55.2	62.1
15	61	200	36.6	45.8	59.5	73.2	82.3
25	48	120	48	60	78	96	108
40	34	75	54	68	88	109	122
50	38	60	76	96	124	152	171
75	25	40	75	94	122	150	168.8

Gear reduction	Efficiency of the gear	Speed at motor-speed 3000rpm	Nominal torque in S3-operation				
			M42x15/I L2 = 70 mm	M42x20/I L2 = 75 mm	M42x30/I L2 = 85 mm	M42x40/I L2 = 95 mm	
[i = x:1]	[%]	[1/min]	[Ncm]	[Ncm]	[Ncm]	[Ncm] 12V	[Ncm] 24V
10	74	300	44.4	55.5	72.2	88.8	99.9
15	68	200	61.2	76.5	99.5	122.4	137.7
25	56	120	84	105	136.5	168	189
40	39	75	94	117	152	187	211
50	42	60	126	158	205	252	284
75	28	40	126	158	205	252	284

General gear data

Material worm wheel		Brass
Maximum torque	[Ncm]	300
Permissible shaft load	[N] (axial / radial)	80 / 200
Gear length	[mm]	40

Stand: 7. Februar 2024 – changes reserved

Motor M42 mit Schneckengetriebe SN17

- Gehäuse aus Aluminium, Schnecke aus gehärtetem Stahl, Fettdauerschmierung, Abtrieb kugellagert, optional zweites Wellenende oder Abtriebswelle rechts
- andere Untersetzungen, Abtriebswellen oder Anschlussleitungen auf Anfrage

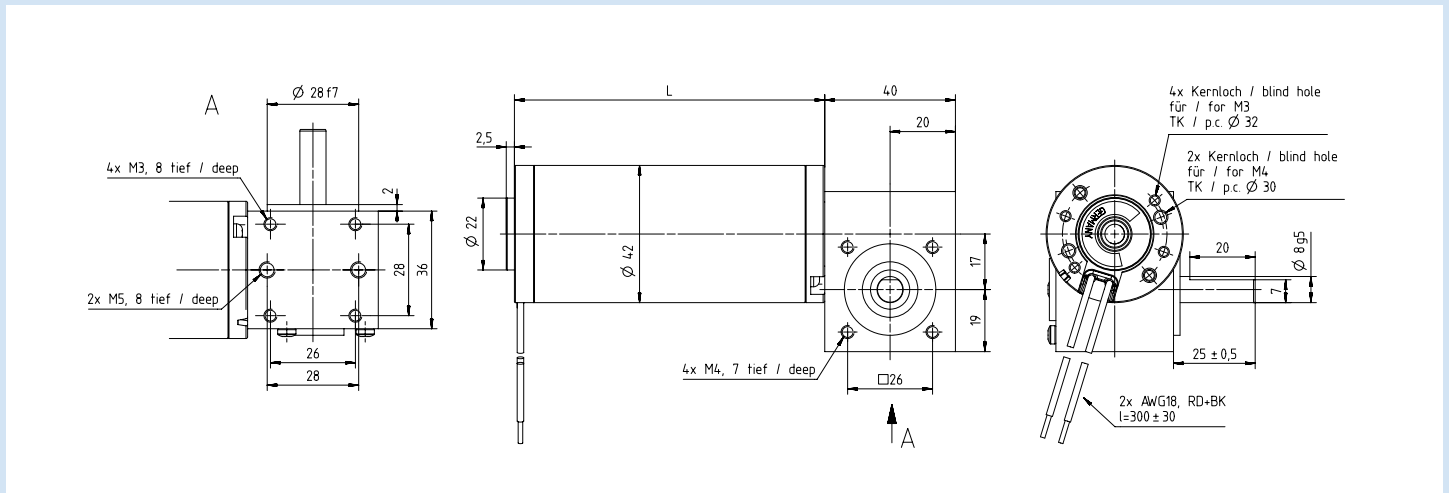

Untersetzungstabelle M42xXX/I+ SN17

Applikation auf Anfrage

Untersetzung	Wirkungsgrad Getriebe	Drehzahl bei Motordrehzahl 3000 1/min	Nenn Drehmoment im S1-Betrieb				
			M42x15/I L = 70 mm	M42x20/I L = 75 mm	M42x30/I L = 85 mm	M42x40/I L = 95 mm	
[i = x:1]	[%]	[1/min]	[Ncm]	[Ncm]	[Ncm]	[Ncm] 12V	[Ncm] 24V
10	69	300	27.6	34.5	44.9	55.2	62.1
15	61	200	36.6	45.8	59.5	73.2	82.3
25	48	120	48	60	78	96	108
40	34	75	54	68	88	109	122
50	38	60	76	96	124	152	171
75	25	40	75	94	122	150	168.8

Untersetzung	Wirkungsgrad Getriebe	Drehzahl bei Motordrehzahl 3000 1/min	Nenn Drehmoment im S3-Betrieb				
			M42x15/I L2 = 70 mm	M42x20/I L2 = 75 mm	M42x30/I L2 = 85 mm	M42x40/I L2 = 95 mm	
[i = x:1]	[%]	[1/min]	[Ncm]	[Ncm]	[Ncm]	[Ncm] 12V	[Ncm] 24V
10	74	300	44.4	55.5	72.2	88.8	99.9
15	68	200	61.2	76.5	99.5	122.4	137.7
25	56	120	84	105	136.5	168	189
40	39	75	94	117	152	187	211
50	42	60	126	158	205	252	284
75	28	40	126	158	205	252	284

Allgemeine Getriebedaten

Material Schneckenrad		Messing
Max. Drehmoment	[Ncm]	300
Zulässige Wellenbelastung	[N] (axial / radial)	80 / 200

Stand: 7. Februar 2024 – Änderungen vorbehalten